

Development of a Lithium-Ion Battery Charging System Under Constant Current and Voltage Conditions Using STM-32 Based on Fuzzy Logic Control

Muhammad Khamim Asy'ari^{1*}, David Keyvin Sabam Halomoan Panggabean¹, Ali Musyafa¹, Kevin Bestian Ginting¹

¹ Engineering Physics Department, Sepuluh Nopember Institute of Technology, Indonesia

Corresponding Authors E-mail: mkasyari@its.ac.id

Article Info

Article info:

Received: 28-09-2024

Revised: 06-01-2025

Accepted: 21-01-2025

Keywords:

Charging system; Current;

Fuzzy logic Control;

Lithium-ion battery;

Voltage.

How To Cite:

M. K. Asy'ari, D. K. S. H.

Panggabean, A. Musyafa,

and K. B. Ginting

"Development of a

Lithium-Ion Battery

Charging System Under

Constant Current and

Voltage Conditions Using

STM-32 Based on Fuzzy

Logic Control", *Indonesian*

Physical Review, vol. 8,

no. 1, p 340-348, 2025.

DOI:

<https://doi.org/10.29303/ip.r.v8i1.409>

Abstract

Lithium-ion batteries are electrical energy storage devices often found in portable electronic equipment. Overcharging and discharging the battery will reduce its life and cause severe damage. Constant current and voltage control methods and control algorithms, such as fuzzy logic control, must be added to avoid this. This research aims to develop a lithium-ion battery charging system using a constant current and voltage method based on fuzzy logic control. A constant current-constant voltage (cc-cv) charging system helps control the charging voltage and current by conditioning the initial charging to use a constant current so as not to overcharge. Constant current uses a buck converter circuit, while constant voltage uses a voltage regulator circuit. The charging system is equipped with a voltage sensor and a current sensor. System control uses fuzzy logic control methods with input variables as errors and delta errors while the output is a duty cycle. The overall system design was carried out at the Measurement, Reliability, Risk, and Safety Laboratory, ITS for 4 months. The test results show that charging the battery produces a voltage of 12.6 Volts and a current of 2.5 Amperes. The battery will be fully charged, and the charging system will stop when the flowing current decreases and the current is cut off at 100 mA.



Copyright (c) 2025 by Author(s). This work is licensed under a Creative Commons Attribution-ShareAlike 4.0 International License.

Introduction

Batteries are a medium for storing electrical energy. Batteries were chosen for energy storage because they have high efficiency and low pollution levels [1]-[3]. There are several types of batteries, one of which is the lithium-ion battery. Lithium-ion batteries are rechargeable and environmentally friendly because they do not contain hazardous materials [4]-[6]. Lithium-ion batteries have many advantages, including charging capacity, volume, and weight

compared to rechargeable batteries. One of the problems in lithium-ion battery research is battery charging, which includes techniques that maximize battery capacity. The commonly used battery charging methods are constant current and voltage [7].

Constant current and constant voltage (CC-CV) is a charging method consisting of two stages: constant current and constant voltage. Constant current will be provided at the start of charging the battery until it reaches the specified voltage limit on the battery. Constant voltage will be provided when the battery has reached a predetermined voltage limit. This causes the current during initial charging to drop to almost zero, and a cut-off will occur, which indicates that the battery is fully charged [8]. The CC-CV method requires an electrical circuit and a control system to be applied. One control method that can be applied is fuzzy logic control [9]-[11]. The CC-CV battery charging method tends to be less flexible in adjusting charging parameters for different types of batteries. Fuzzy logic can overcome this limitation by implementing adaptive rule-based decision-making, allowing current and voltage charging settings based on the actual condition of the battery.

Fuzzy logic control is a control method that is widely used in the field of control systems, especially for nonlinear systems [12]. The fuzzy logic control algorithm requires a controller to be implemented in hardware. STM-32 is a controller that is applicable to use because it has a higher clock frequency and capacity, and the power used is much more efficient [13], [14]. STM32 is more suitable for implementing the CC-CV battery charging method because it has an ARM Cortex-based microcontroller that supports fast and accurate processing to monitor battery parameters such as current and voltage precisely. This research aims to develop a lithium-ion battery charging system using the CC-CV method via STM-32 using fuzzy logic control. The thing that needs to be considered is determining the right duty cycle parameters to determine the shift from constant current to constant voltage method so that the life cycle of the battery can be increased. Applying the CC-CV charging method using fuzzy logic control is expected to improve charging efficiency, extend the service life of lithium-ion batteries, and ensure safer charging under various operational conditions.

Experimental Method

The experimental method consists of two main stages: the design of the battery charging system and the design of fuzzy logic control. The following two stages will be implemented and tested for each component. The overall system was designed and implemented at the Measurement, Reliability, Risk, and Safety Laboratory, ITS, for 4 months from February to June 2021. The instruments used are a DC power supply and a multimeter. The statistical software used is Microsoft Excel to process data and Origin for data visualization.

Design of Battery Charging System

Charging system components include a power supply as a voltage input, a buck converter circuit as a circuit at the constant current stage, a voltage regulator as a circuit at the constant voltage stage, a relay, a voltage sensor, a current sensor, and a lithium-ion battery [15]-[18]. The hardware design stages are divided into two stages, namely, constant current and constant voltage. The first stage is a constant current, consisting of a series of buck converters controlled using a fuzzy logic method so that the output current is 1.2 - 2.5 Amperes. The second stage is in the form of constant voltage, which uses a voltage regulator to produce an output of 12.6 Volt. The schematic diagram of the circuit is shown in Figure 1.

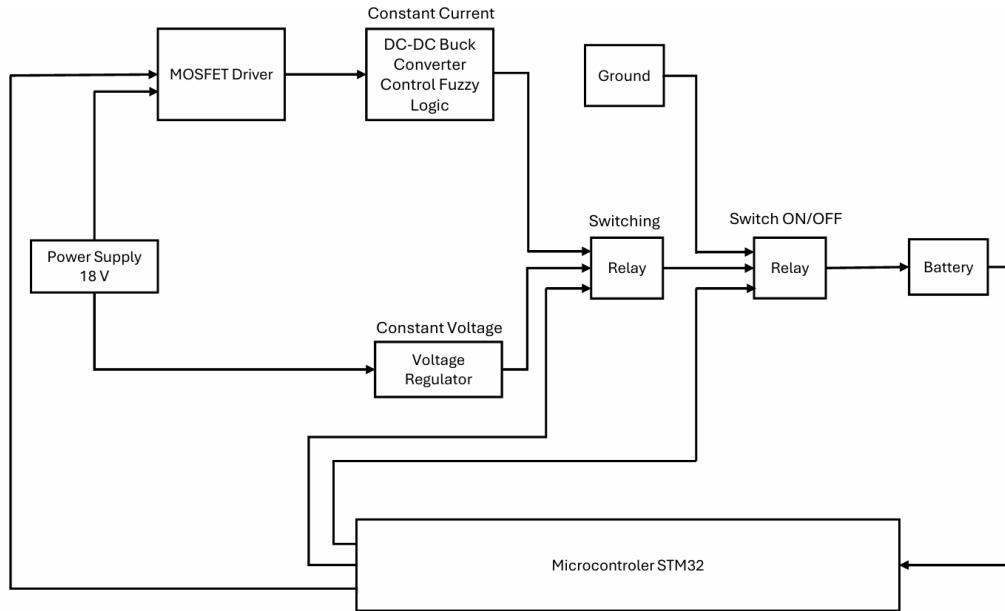

Figure 1. System Charging Scheme

Determination of the value of the components in buck converter design, including the values of capacitors, inductors, and resistors, which are calculated based on [19]–[21]. The input voltage is 18 Volts, and the output voltage is 12.6 Volts. The calculation results for each component used in the battery charging system are shown in Table 1. The buck converter circuit has a voltage sensor to determine the output voltage.

Table 1. System Component and Parameters

System	Component	Value
DC-DC Buck Converter	Mosfet	IRFZ44N
	Diode	6A
	Inductor	300 uH
	Capacitor	100 uF
Switching	Relay	5 Volt Input
Voltage Regulator	LM317	2-30 Volt Output
Sensor	Voltage Sensor	0-25 Volt
	Current Sensor	0-5 A
Battery	Lit-Ion	LG18650 HG2 (3Ah)
PWM Driver	D4184	Continuous Current 15A

The type of MOSFET used in the buck converter circuit is IRFZ44N because it has a maximum drain-source breakdown voltage of 55 Volts and a drain current of 47 Amps. The diode used is a diode that can conduct 6 Ampere current. The selection of MOSFET and diode components maintains safety when used without excessive voltage or current [22], [23]. The battery parameters that need to be considered are the voltage and current supplied and the cut-off value when the battery is fully charged. The battery used is the LG18650 HG2 lit-ion type. The battery specification data has a nominal voltage of 3.6 V, a standard constant current of 1.5 A, and a constant voltage of 4.2 V with a cut-off of 50 mA. Fast charging is carried out

with a constant current of 4 A and a constant voltage of 4.2 V with a cut-off of 100 mA. This battery has a capacity of 3000mAh.

The control of the charging system regulates the duty cycle, which will affect the output voltage in the buck converter circuit. The control method used is Mamdani fuzzy logic. The control signal from the microcontroller is the duty cycle, which will then be sent to the MOSFET gate pin.

Design of fuzzy logic control

Fuzzy logic control (FLC) is used for duty cycle generation, which controls the output voltage on the buck converter so that it has a constant value. FLC has two inputs, namely error and delta error, and an output is the duty cycle. The error is the difference between the output voltage and the setpoint value, while the delta error is the difference between the previous and current errors. The fuzzy inference system is Mamdani with rule 3x3. Mamdani was chosen because it is more intuitive, very flexible with data, and has been used by many parties [24], [25]. The fuzzification results of input and output are shown in Figure 2 and the rule base is shown in Table 2.

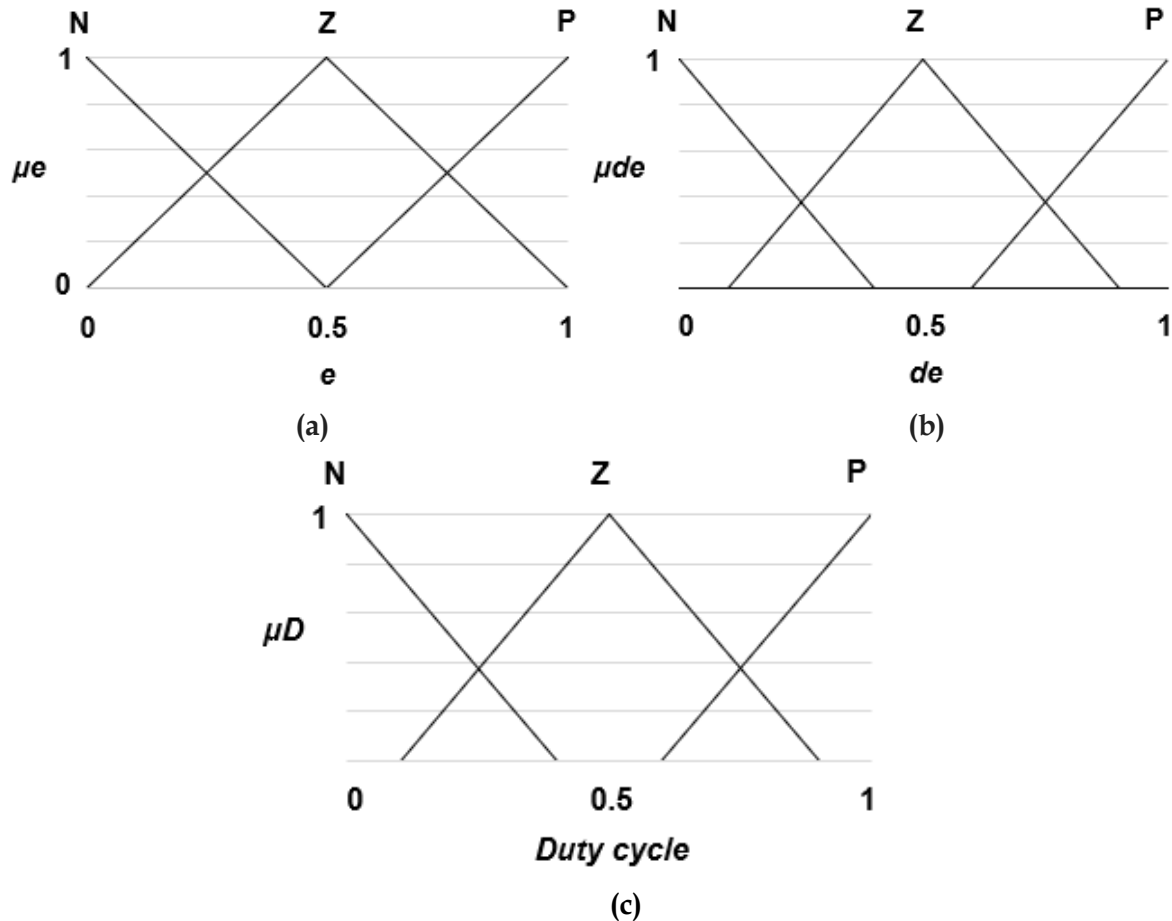

Figure 2. Fuzzy logic control membership functions (a) error, (b) delta error, and (c) duty cycle

Table 2. Rule Base for Fuzzy Logic Control

e/de	N	Z	P
N	N	N	Z
Z	N	Z	P
P	Z	P	P

Results and Discussion

The results of testing the voltage and current sensors are the linearity equation and the maximum hysteresis value as the static characteristics of the sensor. The maximum hysteresis for the voltage sensor is 0.5 percent, and the current sensor is 0.8 percent. The graph of the linearity test results from the two sensors is shown in Figure 3.

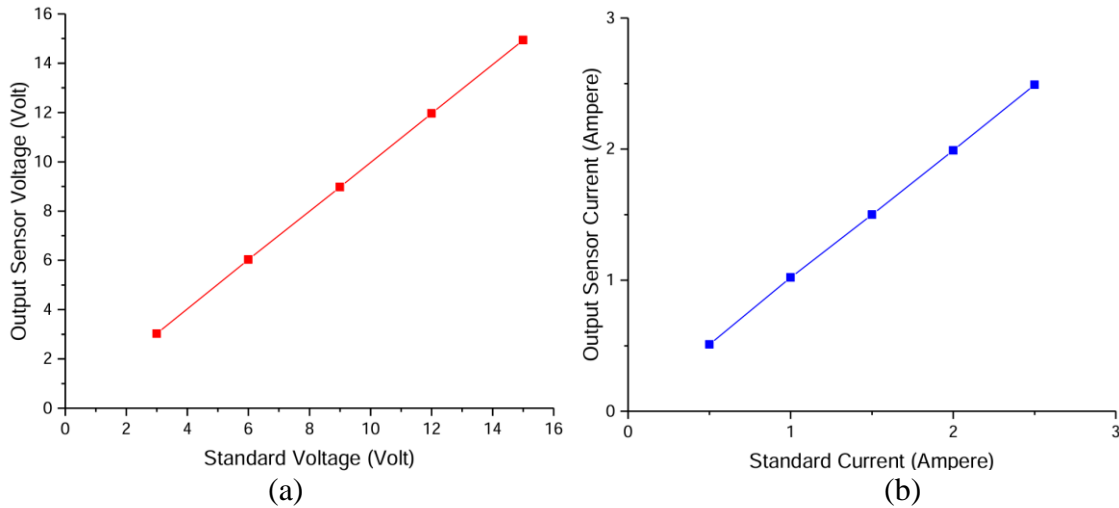

Figure 3. Result of (a) voltage and (b) current sensors testing

Figure 3 shows the linear relationship between sensor output and standard values. The average error produced was 0.04 Volts and 0.01 Ampere. Equations (1) - (2) show the linearity equation for voltage and current.

$$V_{std} = 1.0077V - 0.0533 \tag{1}$$

$$I_{std} = 1.0077I - 0.0533 \tag{2}$$

Equations (1) - (2) show that the coefficient of the regression equation is 1.0077, which indicates that the relationship between the standard value and the sensor value is very close. The regression coefficient value approaching 1 indicates that changes in the standard value are almost wholly followed by similar changes in the measured value, indicating a strong and consistent relationship between the two. A minor correction (0.0077) can be considered a minimal deviation within the tolerance limit. Study [26] has a regression equation coefficient ranging from 0.9402 to 0.9796, indicating a lower value than the results obtained. The accuracy

obtained was 99.6 percent for the voltage sensor and 99.3 percent for the current sensor. Buck converter testing was carried out after sensor testing, and the results are shown in Table 3.

Table 3. Rule Base for Fuzzy Logic Control

Setpoint (Volt)	Input Voltage (Volt)	Duty Cycle	Output Voltage (Volt)	Error (Volt)
12.6	16	0.521	12.87	0.27
	17	0.611	12.95	0.35
	18	0.654	13.03	0.43
	19	0.595	13.11	0.51
	20	0.538	13.19	0.59

Table 3 shows that the buck converter performs well because the error produced is less than 5 percent. The 5 percent error margin was chosen because it is considered small enough to maintain the stability and efficiency of the DC-DC converter without requiring overly complex control. This value ensures a reliable output voltage for most applications, but if the margin is exceeded, the converter may become less efficient, generate excess heat, or damage connected devices. The integration results of the entire system were tested, and the test results shown in Figure 4 were obtained.

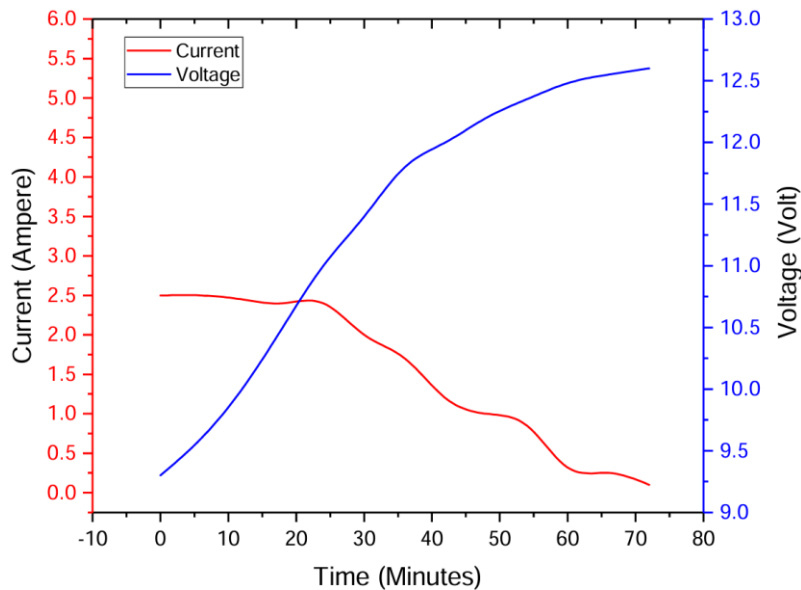

Figure 4. Result of charging curve of the CC-CV using fuzzy logic control

Figure 4 shows that the current is in the range of 0.1 - 2.5 Amperes while the voltage is 9.3 - 12.6 Volts. The current is maintained at 2.5 Amperes in constant current conditions, and the voltage is maintained at 12 Volts in constant voltage conditions. The change from constant current to constant voltage takes 24 minutes. The battery will be fully charged, and the charging system will stop when the flowing current decreases and the current is cut off at 100 mA.

The system that has been built has a sensor accuracy of over 99 percent, and the error generated by the buck converter is less than 5 percent, indicating that the system can produce precise

and stable control. The study began with a simulation of fuzzy logic control conducted by [19] but has not yet progressed to hardware implementation. The accuracy of both sensors is higher than the accuracy of [26], which ranges between 91.94 to 97.7 percent. High accuracy can significantly increase the safety of battery charging because the risk of overcharging or undercharging can be minimized. This system has strengths, including the implementation of fuzzy logic control that can regulate the charging current and voltage based on the actual condition of the battery (adaptive) and the use of STM32 as a microcontroller capable of monitoring the battery current and voltage precisely, while the limitation is that the capacity of the lithium-ion battery used is still relatively small, with a total of 9 Ah, and the input voltage is still constant. Future research is expected to achieve stable current and voltage outputs with varying inputs, such as those from solar panels that fluctuate based on solar irradiation and temperature. Monitoring the state of charge and health should also be integrated into the system.

Conclusion

A lithium-ion battery charging system with fuzzy logic control has been successfully developed. The charging system uses a DC-DC buck converter voltage regulator and STM-32 as a microcontroller by embedding fuzzy logic control. The results show that the system can maintain a current of 2.5 Amperes in constant current conditions and 12 Volts in constant voltage conditions.

Acknowledgment

The author would like to express his most profound gratitude for the financial support from Institut Teknologi Sepuluh Nopember for this work under the research project scheme 2024. "The authors declare no conflict of interest."

References

- [1] S. O. Rey *et al.*, "Powering the Future: A Comprehensive Review of Battery Energy Storage Systems," *Energies*, vol. 16, no. 17, 2023.
- [2] M. Amir *et al.*, "Energy storage technologies: An integrated survey of developments, global economic/environmental effects, optimal scheduling model, and sustainable adaption policies," *J. Energy Storage*, vol. 72, no. PE, p. 108694, 2023.
- [3] A. R. Dehghani-Sanij, E. Tharumalingam, M. B. Dusseault, and R. Fraser, "Study of energy storage systems and environmental challenges of batteries," *Renew. Sustain. Energy Rev.*, vol. 104, no. November 2018, pp. 192–208, 2019.
- [4] F. A. Perdana, "Baterai Lithium," *INKUIRI J. Pendidik. IPA*, vol. 9, no. 2, p. 113, 2021.
- [5] P. Meshram, A. Mishra, Abhilash, and R. Sahu, "Environmental impact of spent lithium ion batteries and green recycling perspectives by organic acids - A review," *Chemosphere*, vol. 242, p. 125291, 2020.
- [6] Y. Yang, E. G. Okonkwo, G. Huang, S. Xu, W. Sun, and Y. He, "On the sustainability of lithium ion battery industry - A review and perspective," *Energy Storage Mater.*, vol. 36, no. December 2020, pp. 186–212, 2021.
- [7] M. Otonog and M. Khudari, "Perancangan Sistem Charging Baterai Lithium-ion

- Mmenggunakan DC-DC Buck Converter Dengan Metode Constant Current-Constant Voltage," *J. Ilm. Setrum Artic. Press*, vol. 10, no. 1, pp. 144-154, 2021.
- [8] Irianto, D. S. Yanaratri, and F. Rahmatullah, "Desain dan Simulasi Battery Charger Metode CC-CV (Constant Current-Constant Voltage) dengan Kontrol Logika Fuzzy Menggunakan MATLAB," *Cyclotron*, vol. 4, no. 2, pp. 18-22, 2021.
- [9] S. Muslimin, R. Maulidda, M. Nawawi, A. Rahman, and P. M. Kurnia, "The Method of Constant Current - Constant Voltage (CC-CV) for SECA Electric Car Battery Charging with Fuzzy Logic Controller," in *Proceedings of the 6th FIRST 2022 International Conference (FIRST-ESCSI-22)*, pp. 14-23, 2023.
- [10] I. G. A. A. Devi Anjani, M. Zaenal Efendi, and O. Asrarul Qudsi, "Design of Battery Charging System with CC-CV Method Using Interleaved Buck-Boost Converter," *J. Electr. Technol. UMY*, vol. 7, no. 1, pp. 38-47, 2024.
- [11] A. Zidan Falih, M. Zaenal Efendi, and F. Dwi Murdianto, "CC-CV Controlled Fast Charging Using Type-2 Fuzzy for Lithium-Ion Battery," *J. Adv. Res. Electr. Eng.*, vol. 5, no. 2, pp. 135-141, 2021.
- [12] A. Khamis *et al.*, "Fuzzy logic implementation with MATLAB for PV-wind hybrid system," *Telkommika (Telecommunication Comput. Electron. Control.*, vol. 15, no. 3, pp. 1181-1191, Sep. 2017.
- [13] H. Ashari and M. Zakarijah, "STM32 Arm Cortex-M Sebagai Media Pembelajaran Mikrokontroler," *J. Elektron. Pendidik. Tek. Elektron.*, vol. 8, no. 1, pp. 10-18, 2019.
- [14] M. J. F. Arifianto and H. Suprpto, "Perancangan Pengendali Gerakan Stepper Motor menggunakan Mikrokontroler STM32 dengan Tampilan Grafis TouchGFX," *J. Fokus Elektroda Energi List. Telekomun. Komputer, Elektron. dan Kendali*, vol. 8, no. 1, pp. 13-20, 2023.
- [15] B. W. A. Mahardika, T. Andromeda, and S. Sudjadi, "Perancangan Sistem Charging Baterai Menggunakan Dc-Dc Buck Converter Metode Constant Current (Cc) Dan Constant Voltage (Cv)," *Transient J. Ilm. Tek. Elektro*, vol. 9, no. 3, pp. 342-350, 2020.
- [16] A. Nasir, M. S. Hamad, and A. K. Elshenawy, "Design and Development of a Constant Current Constant Voltage Fast Battery Charger for Electric Vehicles," in *4th International Conference on Modern Research in Science, Engineering and Technology*, pp. 13-55, 2022.
- [17] D. Reyes-Cruz *et al.*, "High-Gain Step-Down DC-DC Converter Employed in a Battery Charging Application," *IEEE Access*, vol. 11, no. October, pp. 121859-121869, 2023.
- [18] M. Daud, A. Hasibuan, R. S. Hutagalung, and W. K. A. Al-Ani, "Battery charger regulator with fully controlled return 15 V/5 A in uninterruptible power supply," *Int. J. Appl. Power Eng.*, vol. 13, no. 1, pp. 45-51, 2024.
- [19] M. K. Asy'ari and A. Musyafa, "Design of Buck Converter Based on Interval Type-2 Fuzzy Logic Controller," in *2018 International Seminar on Intelligent Technology and Its Applications (ISITIA)*, no. 1, pp. 153-156, 2018.
- [20] M. K. Asy'ari, A. Musyafa', and K. Indriawati, "Design of Wind Turbine Output Voltage Control Systems in Multi-Input Buck Converter Using Fuzzy Logic Control for Battery Charging," in *2019 International Conference on Advanced Mechatronics, Intelligent*

Manufacture and Industrial Automation (ICAMIMIA), pp. 249–252, 2019.

- [21] A. F. Syah, R. I. Mukromin, M. K. Asy'ari, A. Musyafa', and R. D. Noriyati, "Implementation of Multi-Input Buck Converter Voltage Control System Based Fuzzy Logic Control," in *Engineering Physics International Conference – EPIC 2021*, vol. 2580, no. 1, pp. 1–10, 2023.
- [22] Laszlo Balogh, "Fundamentals of MOSFET and IGBT Gate Driver Circuits Application Report," 2017.
- [23] P. B. Green, "Designing with power MOSFETs How to avoid common issues and failure modes About this document," 2022.
- [24] K. Handoko, A. A. Fajrin, and B. Kurniawan, "Penerapan Logika Fuzzy Mamdani Menentukan Kok Terbaik Bulutangkis," *J. Ilm. Inform.*, vol. 06, no. 02, pp. 35–42, 2018.
- [25] M. Irfan, W. Zulfikar, and I. Adrian, "Visualization Quality Achievement Program by Using Inference System Mamdani Method," 2020.
- [26] L. Mohammad, M. K. Asy'ari, M. F. Izdiharrudin, and Suyanto, "Performance Enhancement of Solar Panels Using Adaptive Velocity-Particle Swarm Optimization (AVPSO) Algorithm for Charging Station as an Effort for Energy Security," *Indones. J. Energy*, vol. 3, no. 2, pp. 107–116, 2020.